

TYPE 510

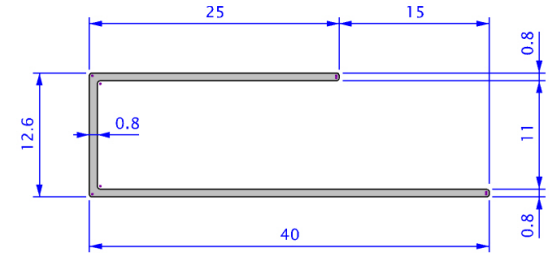
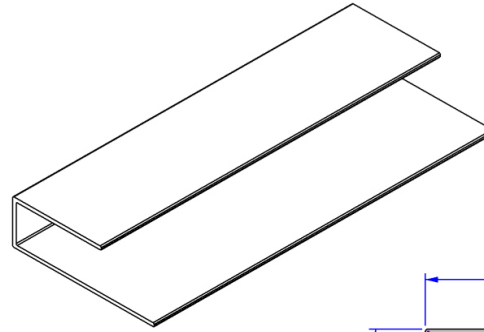
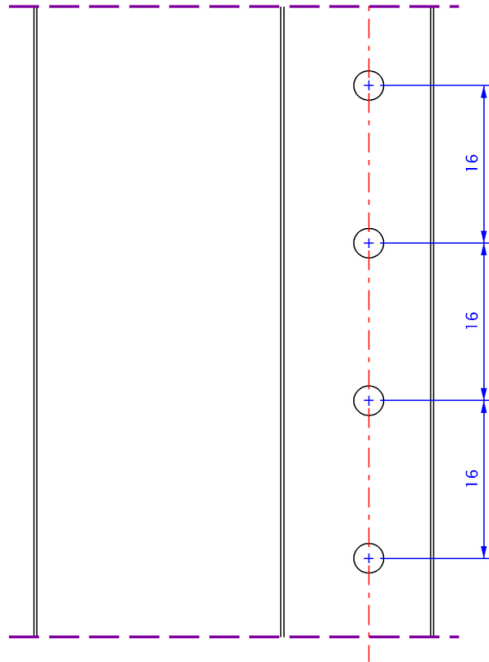
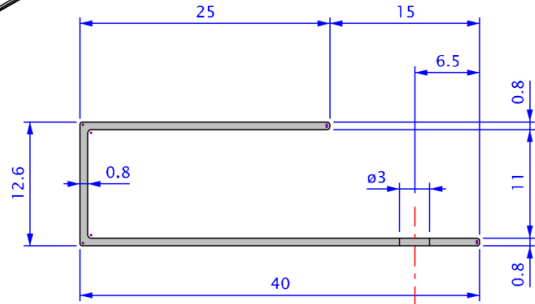
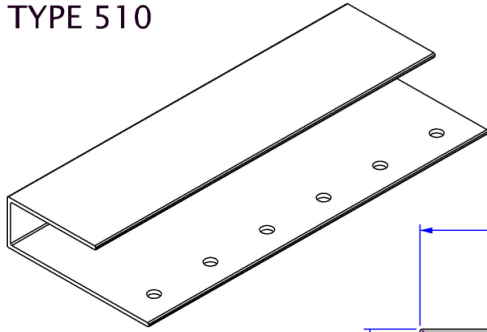

Actual size

Wall thickness	Radius
free	0.3 1.5
0.8	0.5 2.0
0.8	0.8 2.5
1.0	1.0 conc.

26/04/16	DHR	new set, wall thickness to 0.8mm	04
21/10/15	DHR	new set, wall thickness to 0.9mm (was 1mm)	03
13/05/05	DHR	adding punching holes type 510	02
02/12/87	AH	Original	01
Date	ID	Version	

Material	lx / ly (cm4)	Perimeter (mm)	Area/Volume
PVC		152.570	60.7227

Scale	UNPUBLISHED WORK © 2011 DECEUNINCK / THIS DOCUMENT CONTAINS PROPRIETARY AND CONFIDENTIAL INFORMATION. DO NOT COPY OR DISCLOSE THIS INFORMATION WITHOUT THE EXPRESS WRITTEN CONSENT OF DECEUNINCK. DECEUNINCK RESERVES THE RIGHT TO CHANGE THIS DRAWING AND ANY ASSOCIATED DOCUMENTS.	
2/1		
Drawing N°	Papersize	A3
33840	Units	mm

Approved for Production					
Date	/ /	Date	/ /	Date	/ /
Product management		Supplier / DTT		Quality / Operations	

OFFICIAL DRAWING		26/04/2016
Project	Finishing profiles	Product N° 109
Component	start and edge trim	Version 04

