

SPOT ENCASTRABLE BIRDY ORIENTABLE - BÂTIMENT BASSE CONSOMMATION



LAMPE LED INCLUSE
5W=50W

conforme RT2020

BBC
Luminaire testé par
laboratoire CSTB



FLOCABLE



x1
2-3m²

3 ans GARANTIE

30000H L70B50

GU10

DÉCOUPE Ø85mm

220/240 Volts

CE

ALU

INTERCONNECTABLE
Boitier inclus



CONNECTEUR SANS VIS
Installation rapide



ÉTANCHE À L'AIR
BÂTIMENT BASSE CONSOMMATION

 **LES SPOTS BBC SONT COMPATIBLES**
AVEC LES DÉTECTEURS RADIO-FRÉQUENCE ARLUX RÉF. 731640 & 731642

Réf. Arlux	Puissance	Flux Lumineux	Température de Couleur	IRC	Optique	PF	Finition	Diamètre de Découpe	Dimensions
731604	5W	380lm	3000K	>80	36°	>0.5	Blanc	Ø85mm	Ø100x(H)113mm
731605	KIT 3 SPOTS BIRDY (RÉF. 731604) 3 LAMPES GU10 INCLUSES						Blanc	Ø85mm	Ø100x(H)113mm
731606	5W	380lm	3000K	>80	36°	>0.5	Acier	Ø85mm	Ø100x(H)113mm

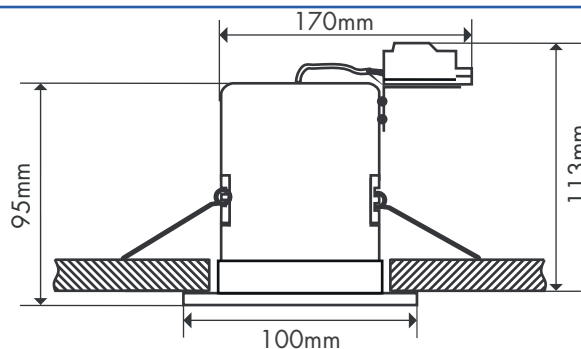

Ref.731604 / 731605 / 731606